

CAHV-R450YA-HPB

Ecodan Air Source Heat Pump

The Mitsubishi Electric Ecodan **CAHV air source heat pump** uses low GWP R454C refrigerant, offering a robust, low carbon system for the provision of sanitary hot water and space heating. This innovative heat pump solution can operate as a single system or form part of a multiple unit system, making it suitable for most commercial applications.

The multiple unit system has the ability to cascade available units to both on and off mode to meet the load from a building. As an example of this unique modulation, a 16 unit system allows 0.5kW increments of capacity, from 7.8kW all the way up to 640kW*. With cascade and rotation built in as standard, the Ecodan CAHV system is perfectly suited to commercial applications including schools and hospitals.



*At nominal conditions A7W35

Key Features & Benefits:

- Low GWP R454C refrigerant and reduced embodied carbon helps achieve CSR targets
- Achieves 70°C outlet temperature down to -20°C ambient temperature for continuous heating provision
- Multiple unit cascade control from 7.8kW to 640kW capacity provides design flexibility for a wide range of commercial applications
- Water flow temperatures from 24°C to 70°C without boost heaters results in cost and energy savings
- Advanced heat exchange design combined with the properties of R454C refrigerant enables a shorter defrost time
- Low frequency compressor control improves energy efficiency and product operation
- Ability to rotate units based on accumulated run hours offers extended product life
- Requires only water and electrical connections, for ease of installation
- Hermetically-sealed monobloc design, requiring low maintenance





MODEL		CAHV-R450YA-HPB	
Power source		3-phase 4-wire 380-400-415V 50/60 Hz	
Capacity(EN14511) ^{*1}	kW	40	
	Power input	kW	
	Current input	A	
	COP (kW/kW)	2.85	
	SCOP Low/Medium	3.57/3.24	
Capacity ^{*2}	kW	33.4	
	Power input	kW	
	Current input	A	
	COP (kW/kW)	2.01	
Maximum current input	A	44.0-41.8-40.3	
Water pressure drop ^{*1}		10.2 kPa (1.47 psi)	
Temperature range ^{*5}	Outlet water temperature	24-70°C	
	Outdoor temperature	-25-43°C	
Circulating water volume range ^{*5}		25 l/min-250 l/min	
Sound pressure level (measured 1m below the unit in an anechoic room) ^{**4}	dB (A)	64	
Sound pressure level (measured 1m below the unit in an anechoic room) ^{**4}	dB (A)	72	
Water pipe diameter and type	Inlet	mm (in)	
	Outlet	mm (in)	
External finish		Acrylic painted steel sheet <Munsell 5Y 8/1 or similar>	
External dimensions H × W × D	mm	1710 × 1750 × 740	
Net weight	kg (lbs)	359 (791)	
Design pressure	R454C	MPa	
	Water	MPa	
Heat exchanger	Water-side	Copper brazed stainless steel sheet	
	Air-side	Plate fins and copper tubes	
Compressor	Type	Inverter scroll hermetic compressor	
	Manufacturer	MITSUBISHI ELECTRIC CORPORATION	
	Starting method	Inverter	
	Motor output	kW	
	Lubricant	FVC32EA	
Fan	Air flow rate	L/s	
	External static pressure	Pa	
	Type and quantity	Propeller fan × 2	
	Control and driving mechanism	Inverter control, direct driven by motor	
	Motor output	kW	
HIC (Heat inter-changer) circuit		Copper pipe	
Protection devices	High pressure	High-pressure sensor and switch set at 3.85 MPa (643 psi)	
	Inverter circuit	Overheat and overcurrent protection	
	Compressor	Overheat protection	
	Fan motor	Thermal switch	
Defrosting method		Auto-defrost mode (Reversed refrigerant cycle)	
Refrigerant	Type and factory charge	kg	
	Flow and temperature control	LEV and HIC circuit	

Notes:

*1 Under normal heating conditions at the outdoor temperature of 7°CDB/6°CWB, the outlet water temperature of 45°C, and the inlet water temperature of 40°C.

*2 Under normal heating conditions at the outdoor temperature of -5°CDB/-6°CWB and the outlet water temperature of 55°C.

*3 Under normal heating conditions at the outdoor temperature of 7°CDB/6°CWB when the unit is set to the "Capacity Priority" mode through the dry NC-contact.

*4 The sound pressure level is a value measured in an anechoic room in accordance with the conventional method in JRA4060.

*5

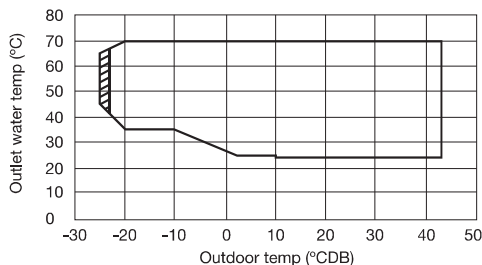

Outdoor temp. -25°CDB/Outlet water temp. 45-65°C
 Outdoor temp. -20°CDB/Outlet water temp. 35-70°C
 Outdoor temp. 43°CDB/Outlet water temp. 24-70°C

*6 4.0 - 15.0 m³/h under the following conditions:

- When the outdoor temperature is below 0°C,
- When the outlet water temperature is 30°C or below AND the outdoor temperature is 6°C or below.



CAHV-R450YA-HPB DIMENSIONS

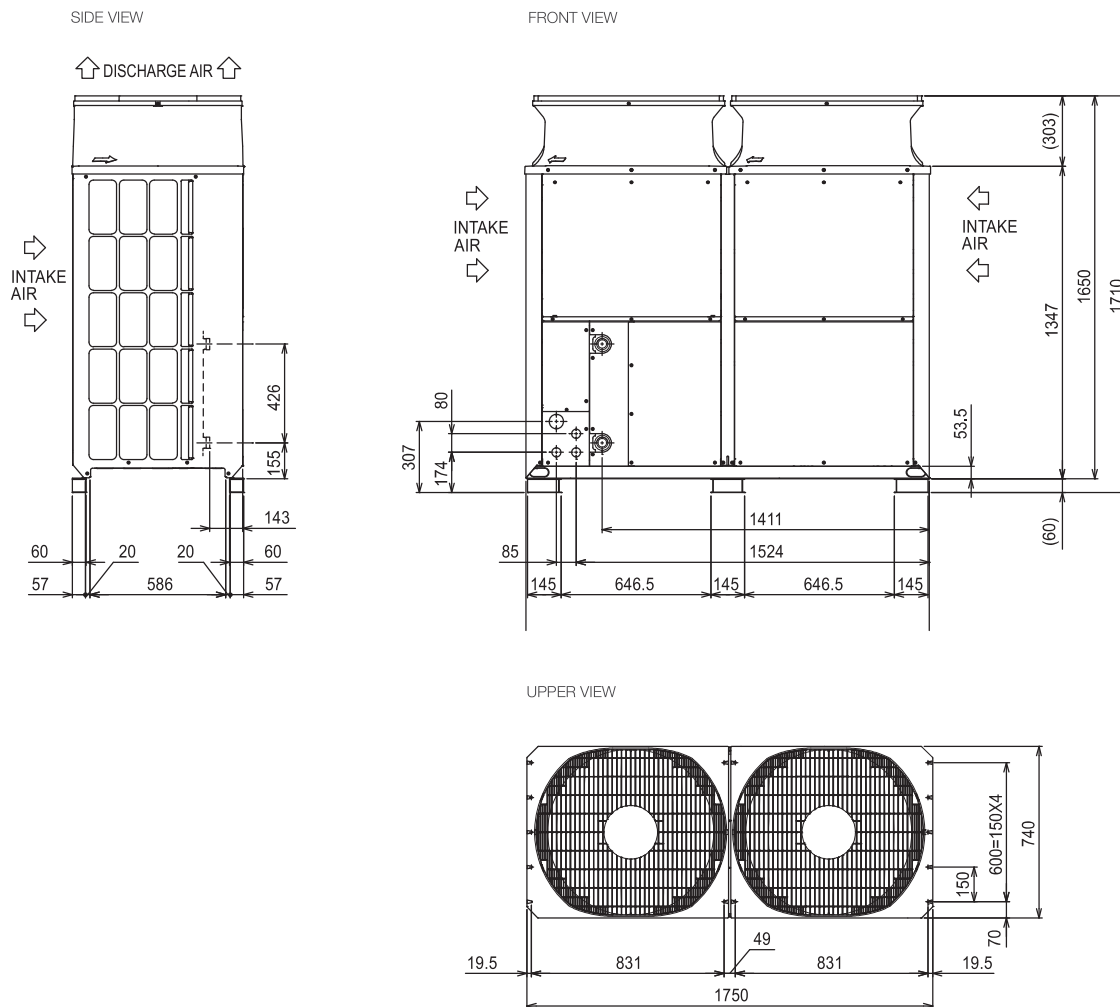

Telephone: 01707 282880
email: air.conditioning@meuk.mee.com
les.mitsubishielectric.co.uk



@meuk_les
[@green_gateway](https://twitter.com/green_gateway)



Mitsubishi Electric Living
Environmental Systems UK



Mitsubishi Electric
Cooling and Heating UK



[mitsubishielectricuk_les](https://www.instagram.com/mitsubishielectricuk_les)



Mitsubishi Electric Living
Environmental Systems UK



thehub.mitsubishielectric.co.uk

UNITED KINGDOM Mitsubishi Electric Europe Living Environment Systems Division, Travellers Lane, Hatfield, Hertfordshire, AL10 8XB, England. Telephone: 01707 282880 Fax: 01707 278881
IRELAND Mitsubishi Electric Europe, Westgate Business Park, Ballymount, Dublin 24, Ireland. Telephone: (01) 419 8800 Fax: (01) 419 8890 International code: (003531)

Country of origin: United Kingdom - Italy - Turkey - Japan - Thailand - Malaysia. ©Mitsubishi Electric Europe 2022. Mitsubishi and Mitsubishi Electric are trademarks of Mitsubishi Electric Europe B.V. The company reserves the right to make any variation in technical specification to the equipment described, or to withdraw or replace products without prior notification or public announcement. Mitsubishi Electric is constantly developing and improving its products. All descriptions, illustrations, drawings and specifications in this publication present only general particulars and shall not form part of any contract. All goods are supplied subject to the Company's General Conditions of Sale, a copy of which is available on request. Third-party product and brand names may be trademarks or registered trademarks of their respective owners.

Note: Refer to 'Installation Manual' and 'Instruction Book' for further 'Technical Information'. The fuse rating is for guidance only and please refer to the relevant databook for detailed specification. It is the responsibility of a qualified electrician/electrical engineer to select the correct cable size and fuse rating based on current regulation and site specific conditions. Mitsubishi Electric's air conditioning equipment and heat pump systems contain a fluorinated greenhouse gas, R410A (GWP:2088), R32 (GWP:675), R407C (GWP:1774), R134a (GWP:1430), R513A (GWP:631), R454B (GWP:466), R1234ze (GWP:7) or R1234yf (GWP:4). *These GWP values are based on Regulation (EU) No 517/2014 from IPCC 4th edition. In case of Regulation (EU) No.626/2011 from IPCC 3rd edition, these are as follows. R410A (GWP:1975), R32 (GWP:550), R407C (GWP:1650) or R134a (GWP:1300).

Effective as of November 2022



Ecodan R32

Monobloc Air Source Heat Pump

R32

Key Features:

- A+++ heating efficiency (Range A+++ to D)
- Compact design
- Maintains full heating capacity at low temperatures
- Zero carbon solution
- MELCloud enabled

Key Benefits:

- Ultra low running cost
- Minimal installation space required
- Confident and quick product selection
- Help to tackle the climate crisis
- Remote control, monitoring, maintenance and technical support



ecodan[®]
Renewable Heating Technology

OUTDOOR UNIT		PUZ-HWM140VHA(-BS)
HEAT PUMP SPACE HEATER - 55°C	ErP Rating	A++ (Range A+++ to D)
	η_s	131%
	SCOP (MCS)	3.26
HEAT PUMP SPACE HEATER - 35°C	ErP Rating	A+++ (Range A+++ to D)
	η_s	176%
	SCOP (MCS)	4.33
HEAT PUMP COMBINATION HEATER - Large Profile ¹	ErP Rating	A+ (Range A+ to F)
	η_{wh}	130%
	Capacity (kW)	14
	Power Input (kW)	5.71
HEATING ² (A-7/W35)	COP	2.45
	OPERATING AMBIENT TEMPERATURE (°C DB)	-28 ~ +35
SOUND DATA ³	Pressure Level at 1m (dBA)	53
	Power Level (dBA) ⁴	67
WATER DATA	Pipework Size (mm)	28
	Flow Rate (l/min)	40.1
	Water Pressure Drop (kPa)	20
DIMENSIONS (mm)	Width	1020
	Depth	330 + 30*7
	Height	1350
WEIGHT (kg)		132
ELECTRICAL DATA	Electrical Supply	220-240v, 50Hz
	Phase	Single
	Nominal Running Current [MAX] (A) ⁵	13.8 [35]
	Fuse Rating - MCB Sizes (A) ⁶	40
REFRIGERANT CHARGE (kg) / CO ₂ EQUIVALENT (t)	R32 (GWP 675)	3.3

Notes:

- *1 Combination with E*PT20X Cylinder
- *2 Under normal heating conditions at outdoor temp: -7°CDB / -8°CWB, outlet water temp 35°C, inlet water temp 30°C.
- *3 Under normal heating conditions at outdoor temp: 7°CDB / 6°CWB, outlet water temp 55°C, inlet water temp 47°C as tested to BS EN14511.
- Low Noise mode accessory (reference PAC-SA89TA-EP) available for VHA chassis.
- *4 Sound power level tested to BS EN12102.
- *5 Under nominal heating conditions at outdoor temp: 7°C, outlet water temp: 35°C.
- *6 MCB Sizes BS EN60898-2 & BS EN60947-2.
- *7 Grille.

η_s is the seasonal space heating energy efficiency (SSHEE) η_{wh} is the water heating energy efficiency

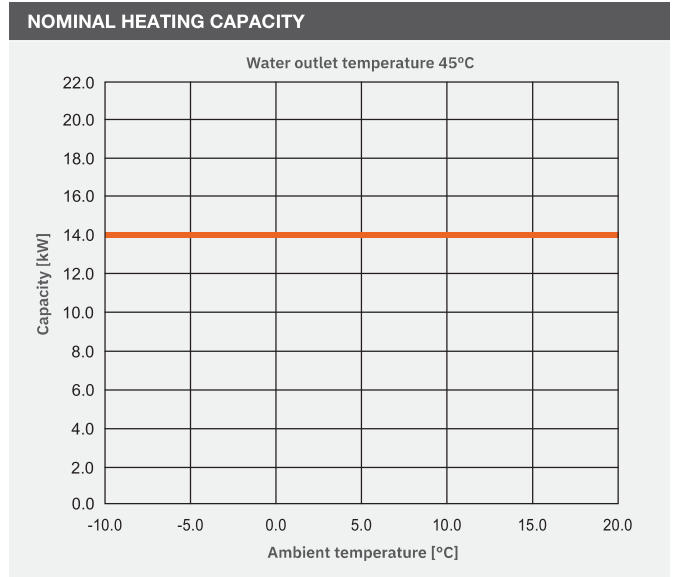

PUZ-HWM140VHA(-BS) DIMENSIONS

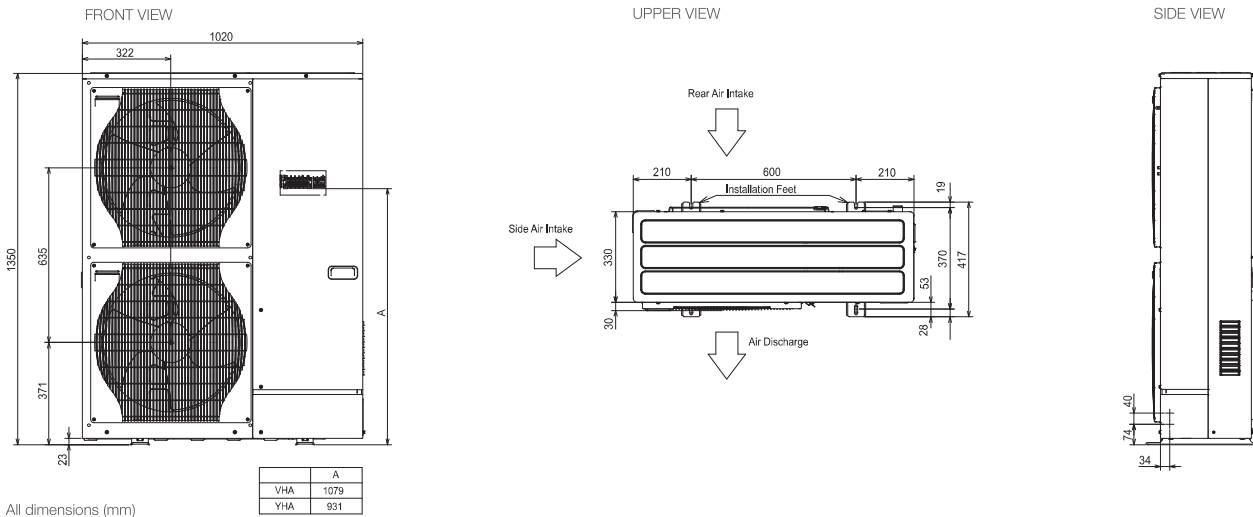

Telephone: 01707 282880
email: heating@meuk.mee.com
heating.mitsubishielectric.co.uk



Mitsubishi Electric Living Environmental Systems UK



Mitsubishi Electric Cooling and Heating UK



[mitsubishielectricuk_les](https://www.instagram.com/mitsubishielectricuk_les)



Mitsubishi Electric Living Environmental Systems UK



thehub.mitsubishielectric.co.uk

UNITED KINGDOM Mitsubishi Electric Europe Living Environment Systems Division, Travellers Lane, Hatfield, Hertfordshire, AL10 8XB, England. Telephone: 01707 282880 Fax: 01707 278881
IRELAND Mitsubishi Electric Europe, Westgate Business Park, Ballymount, Dublin 24, Ireland. Telephone: (01) 419 8800 Fax: (01) 419 8890 International code: (003531)

Country of origin: United Kingdom - Japan - Thailand - Malaysia. ©Mitsubishi Electric Europe 2020. Mitsubishi and Mitsubishi Electric are trademarks of Mitsubishi Electric Europe B.V. The company reserves the right to make any variation in technical specification to the equipment described, or to withdraw or replace products without prior notification or public announcement. Mitsubishi Electric is constantly developing and improving its products. All descriptions, illustrations, drawings and specifications in this publication present only general particulars and shall not form part of any contract. All goods are supplied subject to the Company's General Conditions of Sale, a copy of which is available on request. Third-party product and brand names may be trademarks or registered trademarks of their respective owners.

Note: Refer to 'Installation Manual' and 'Instruction Book' for further 'Technical Information'. The fuse rating is for guidance only and please refer to the relevant databook for detailed specification. It is the responsibility of a qualified electrician/electrical engineer to select the correct cable size and fuse rating based on current regulation and site specific conditions. Mitsubishi Electric's air conditioning equipment and heat pump systems contain a fluorinated greenhouse gas, R410A (GWP:2088), R32 (GWP:675), R407C (GWP:1774), R134a (GWP:1430), R513A (GWP:631), R454B (GWP:466), R1234ze (GWP:7) or R1234yf (GWP:4). These GWP values are based on Regulation (EU) No 517/2014 from IPCC 4th edition. In case of Regulation (EU) No 626/2011 from IPCC 3rd edition, these are as follows. R410A (GWP:1975), R32 (GWP:550), R407C (GWP:1650) or R134a (GWP:1300).

Effective as of January 2025





OUTDOOR UNIT		QAHV-N560YA-HPB	
WATER HEATING 65°C ¹	CAPACITY (kW)	40	
	POWER INPUT (kW)	10.31	
	CURRENT INPUT (A)	16.3	
	COP	3.88	
WATER HEATING 65°C ²	CAPACITY (kW)	40	
	POWER INPUT (kW)	10.97	
	CURRENT INPUT (A)	18.3	
	COP	3.65	
WATER HEATING 65°C ³	CAPACITY (kW)	40	
	POWER INPUT (kW)	11.6	
	CURRENT INPUT (A)	18.7	
	COP	3.44	
WATER HEATING ENERGY EFFICIENCY CLASS TEMPERATURE RANGE	FOR MEDIUM TEMPERATURE APPLICATION	A	
	INLET WATER TEMPERATURE (°C)	5 ~ 63	
	OUTLET WATER TEMPERATURE (°C)	55 ~ 90	
	OUTDOOR TEMPERATURE (°C)	-25~43	
ELECTRICAL	MAX CURRENT INPUT (A)	33.8	
	ELECTRICAL SUPPLY (V / Hz)	380-415v, 50Hz	
	PHASE	3	
	FUSE RATING - MCB SIZES (A) ⁵	40	
WATER DETAIL	INLET / OUTLET (mm (in.))	19.05 (Rc 3/4"), screw pipe / 19.05 (Rc 3/4"), screw pipe	
	ALLOWABLE EXTERNAL PUMP HEAD (kPa)	77	
DIMENSIONS (mm)	WIDTH	1220	
	DEPTH	760	
	HEIGHT	1837 (1777 without legs)	
WEIGHT (kg)	400		
NOISE LEVEL	SOUND PRESSURE ⁴ (dB(A))	56	
REFRIGERANT	TYPE	R744 (GWP 1)	
	REFRIGERANT CHARGE (kg) / CO ₂ EQUIVALENT (t)	6.5 / 0.0065	

Notes: ¹ Under Normal heating conditions at the outdoor temp, 16°CDB/12°CWB, the outlet water temperature 65°C, and the inlet water temperature 17°C.
² Under Normal heating conditions at the outdoor temp, 7°CDB/6°CWB, the outlet water temperature 65°C, and the inlet water temperature 9°C.
³ Under Normal heating conditions at the outdoor temp, 7°CDB/6°CWB, the outlet water temperature 65°C, and the inlet water temperature 15°C.
⁴ Measured 1m from the front of the unit in an anechoic room. ⁵ MCB Sizes BS EN60898-2 & BS EN60947-2

QAHV-N560YA-HPB DIMENSIONS

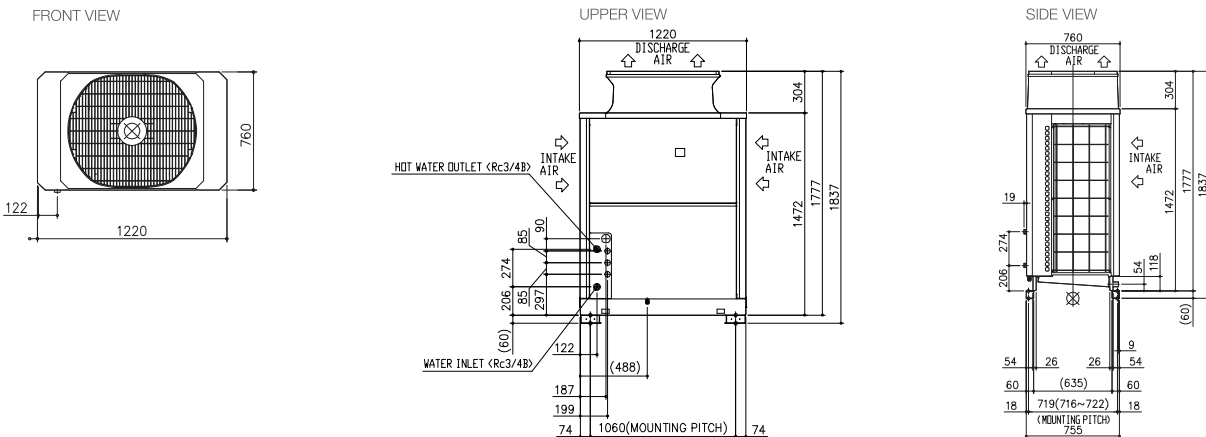

Telephone: 01707 282880
 email: air.conditioning@meuk.mee.com
les.mitsubishielectric.co.uk



UNITED KINGDOM Mitsubishi Electric Europe Living Environment Systems Division, Travellers Lane, Hatfield, Hertfordshire, AL10 8XB, England. Telephone: 01707 282880 Fax: 01707 278881
 IRELAND Mitsubishi Electric Europe, Westgate Business Park, Ballymount, Dublin 24, Ireland. Telephone: (01) 419 8800 Fax: (01) 419 8890 International code: (003531)

Country of origin: United Kingdom - Japan - Thailand - Malaysia. ©Mitsubishi Electric Europe 2020. Mitsubishi and Mitsubishi Electric are trademarks of Mitsubishi Electric Europe B.V. The company reserves the right to make any variation in technical specification to the equipment described, or to withdraw or replace products without prior notification or public announcement. Mitsubishi Electric is constantly developing and improving its products. All descriptions, illustrations, drawings and specifications in this publication present only general particulars and shall not form part of any contract. All goods are supplied subject to the Company's General Conditions of Sale, a copy of which is available on request. Third-party product and brand names may be trademarks or registered trademarks of their respective owners.

Note: The fuse rating is for guidance only. Please refer to the relevant databook for detailed specification. It is the responsibility of a qualified electrician/electrical engineer to select the correct cable size and fuse rating based on current regulation and site specific conditions. Mitsubishi Electric's air conditioning equipment and heat pump systems contain a fluorinated greenhouse gas, R410A (GWP:2088), R32 (GWP:675), R407C (GWP:1774) or R134a (GWP:1430). *These GWP values are based on Regulation (EU) No 517/2014 from IPCC 4th edition. In case of Regulation (EU) No.626/2011 from IPCC 3rd edition, these are as follows. R410A (GWP:1975), R32 (GWP:550), R407C (GWP:1650) or R134a (GWP:1300).

Effective as of May 2020





The MYSON LST is the UK's most comprehensive and popular range of LST radiators, with both horizontal and vertical options available. The range is compliant with NHS Estates Guidance Notes 1998 and comes with anti-bacterial paint, making it ideal for hospital and care home applications. The LST range is also suitable for schools, student accommodation and other social housing projects as the surface temperature remains below 43°C and comes with safety conscious round steel casing, which eliminates sharp edges and ensures pipe work is concealed.

- The MYSON LST is available in 94 sizes
- It is available in three types, Super, Super Extra and Super Plus
- There are six different heights ranging from 572mm to 2072mm
- We offer selected models in length 420mm, which is the slimmest panel LST radiator on the market today, through to 2200mm, the widest panel LST radiator



LST RANGE (LOW SURFACE TEMPERATURE)

LST

Heat outputs

LST SUPER - Nominal Depth 107mm

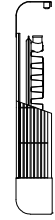

Nominal Height	Outer Casing Nominal Length (mm)	Heat Outputs @ ΔT 50°C	Heat Outputs @ ΔT 30°C	Order Code				
		Watts	Btu/h					
572mm	800	277	946	139	475	5 LS 080	Order Code	
	1000	370	1261	186	634	5 LS 100	5.LSP.080	
	1200	462	1576	232	792	5 LS 120	5.LSP.100	
	1400	554	1890	278	949	5 LS 140	5.LSP.120	
	1600	647	2207	325	1109	5 LS 160	5.LSP.140	
	1800	739	2521	371	1266	5 LS 180	5.LSP.160	
	2000	832	2837	418	1426	5 LS 200	5.LSP.180	
	2200	925	3153	464	1586	5 LS 220*	5.LSP.200	
	672mm	800	243	830	123	418	6 LS 060	Order Code
		1000	385	1245	184	627	6 LS 080	6.LSP.060
1200		486	1660	245	836	6 LS 100	6.LSP.080	
1400		587	2074	306	1045	6 LS 120	6.LSP.100	
1600		688	2489	368	1254	6 LS 140	6.LSP.120	
1800		789	2904	429	1463	6 LS 160	6.LSP.140	
2000		890	3319	490	1672	6 LS 180	6.LSP.160	
2200		991	3734	551	1881	6 LS 200	6.LSP.180	
872mm		800	353	1205	179	610	8 LS 060	Order Code
		1000	530	1808	268	915	8 LS 080	8.LSP.060
	1200	706	2410	358	1221	8 LS 100	8.LSP.080	
	1400	883	3013	447	1526	8 LS 120	8.LSP.100	
	1600	1060	3615	537	1831	8 LS 140	8.LSP.120	
	1800	1236	4218	626	2136	8 LS 160	8.LSP.140	
	2000	1413	4820	716	2441	8 LS 180	8.LSP.160	
	2200	1589	5423	805	2746	8 LS 200	8.LSP.180	
	1022mm	800	353	1205	179	614	10 LS 042	Order Code
		1000	471	1608	240	819	10 LS 060	10.LSP.042
1200		589	2011	301	1024	10 LS 080	10.LSP.060	
1400		707	2412	360	1228	10 LS 100	10.LSP.080	
1600		825	2815	420	1432	10 LS 120	10.LSP.100	
1800		942	3215	480	1638	10 LS 140	10.LSP.120	
2000		1060	3615	537	1831	10 LS 160	10.LSP.140	
2200		1178	4019	600	2047	10 LS 180	10.LSP.160	
LST SUPER EXTRA - Nominal Depth 127 mm		800	353	1205	179	614	8 LS 220*	Order Code
		1000	530	1808	268	915	8 LS 220*	8.LSP.220*
	1200	706	2410	358	1221	8 LS 220*	8.LSP.220*	
	1400	883	3013	447	1526	8 LS 220*	8.LSP.220*	
	1600	1060	3615	537	1831	8 LS 220*	8.LSP.220*	
	1800	1236	4218	626	2136	8 LS 220*	8.LSP.220*	
	2000	1413	4820	716	2441	8 LS 220*	8.LSP.220*	
	2200	1589	5423	805	2746	8 LS 220*	8.LSP.220*	
	LST SUPER PLUS - Nominal Depth 157mm	800	353	1205	179	614	10 LS 200	Order Code
		1000	471	1608	240	819	10 LS 200	10.LSP.200
1200		589	2011	301	1024	10 LS 200	10.LSP.200	
1400		707	2412	360	1228	10 LS 200	10.LSP.200	
1600		825	2815	420	1432	10 LS 200	10.LSP.200	
1800		942	3215	480	1638	10 LS 200	10.LSP.200	
2000		1060	3615	537	1831	10 LS 200	10.LSP.200	
2200		1178	4019	600	2047	10 LS 200	10.LSP.200	

LST SUPER PLUS - Nominal Depth 157mm



Heat Outputs @ ΔT 50°C	Heat Outputs @ ΔT 30°C	Order Code		
Watts	Btu/h	Watts	Btu/h	
545	1861	276	942	5.LSP.080
727	2481	368	1256	5.LSP.100
909	3102	460	1571	5.LSP.120
1091	3722	552	1883	5.LSP.140
1273	4342	644	2199	5.LSP.160
1454	4961	736	2511	5.LSP.180
1636	5583	829	2827	5.LSP.200
468	1597	238	811	6.LSP.060
702	2395	357	1217	6.LSP.080
936	3194	475	1622	6.LSP.100
1170	3992	594	2028	6.LSP.120
1404	4790	713	2433	6.LSP.140
1638	5589	832	2839	6.LSP.160
1872	6387	951	3244	6.LSP.180
2106	7186	1070	3650	6.LSP.200
2340	7984	1188	4053	6.LSP.220
659	2249	337	1150	8.LSP.060
989	3374	505	1724	8.LSP.080
1318	4498	674	2299	8.LSP.100
1648	5623	842	2874	8.LSP.120
1978	6748	1011	3449	8.LSP.140
2307	7872	1179	4023	8.LSP.160
2637	8997	1348	4598	8.LSP.180
2966	10121	1516	5173	8.LSP.200
3296	11245	1684	5746	8.LSP.220
556	1896	278	948	10.LSP.042
741	2528	370	1264	10.LSP.060
1111	3791	556	1896	10.LSP.080
1482	5055	741	2528	10.LSP.100
1852	6319	926	3160	10.LSP.120
2222	7583	1111	3791	10.LSP.140
2593	8847	1296	4423	10.LSP.160
2963	10110	1482	5055	10.LSP.180
3334	11374	1667	5687	10.LSP.200

*Non-stock - made to order only.

LST

Valves & controls

MYSON offer a range of thermostatic valves designed to maximise the effectiveness of our range of Low Surface Temperature radiators. Three designs are available, the Universal Close Coupled and the Close Coupled Kit which

allows the case to be removed for cleaning without removing the TRV head, and the competitively priced Direct Fit Kit.

Direct fit TRV kit

Available for all LST's except Vertical and 420mm wide. Suitable for TBQE connection only. This kit allows a MYSON TRV to be mounted directly onto the internal radiator, making it an integral part of the LST radiator. This option utilises the 38mm knock out in the LST casing.

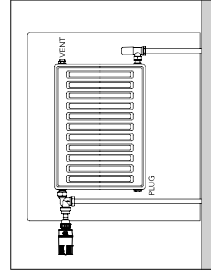

- Direct Fit TRV Kit comprises:**
- 1 x Horizontal angle TRV body
 - 1 x TRV head
 - 1 x Extension adaptor
 - 1 x Plastic bush
 - 1 x MATCHMASTER lockshield valve
- Order Code: LSTDIRECTKITUK**

Close coupled TRV kit

Available for all LST's except Vertical and 420mm wide. Suitable for TBQE, TBSE or BOE connections. This kit allows the MYSON TRV to be mounted directly onto the LST casing, with a choice of positions for both the TRV head and TRV angled valve body. This option utilises the 23mm knock out on the LST casing.

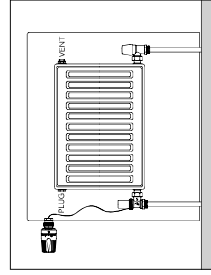

- Close Coupled TRV Kit comprises:**
- 1 x TRV head*
 - 1 x TRV angled body*
 - 1 x LST capillary unit/actuator/sensor head adaptor
 - 1 x MATCHMASTER angled lockshield valve
 - 1 x Locking tool
- Order Code: LSTCKITUK**

Universal close coupled TRV kit

Available for all LST's. Suitable for TBQE, TBSE or BOE connections. This kit allows the MYSON TRV to be mounted directly onto the LST casing, with a choice of positions for both the TRV head and TRV straight valve body. This option utilises the 23mm knock out on the LST casing.

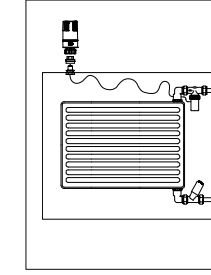







- Universal Close Coupled TRV Kit Comprises:**
- 1 x TRV head*
 - 1 x TRV straight body*
 - 1 x LST capillary unit/actuator/sensor head adaptor
 - 1 x MATCHMASTER straight lockshield valve
 - 2 x Integration elbows
- Order Code: LSTUNIKITUK**







Please see page 244 for more information.

*15mm compression cooper only - for 1/2" non pipe, an additional female adaptor is required.

LST VERTICAL

General specification & technical information

-  **CERTIFICATION**
Manufactured and tested to BS EN 442 & EN 442. Carries the CE & UKCA Mark. Produced under a quality management system - ISO 9001:2015, environmental management system - ISO 14001:2015 and Occupational health and safety management system - ISO 45001:2018.
-  **GUARANTEE**
10 year guarantee from date of purchase against manufacturing defects for both the radiator and the casing.
-  **COLOUR**
All radiators are de-greased, phosphated and primer coated. An epoxy polyester finishing coat in white (RAL 9016) is applied to all front and rear surfaces.
-  **ANTI-BACTERIAL PAINT**
Coating to suppress bacterial growth.
-  **ACCESSORIES**
Touch up paint is available to order.
-  **SYSTEM**
2 pipe pumped indirect domestic and commercial heating applications.

-  **CONNECTIONS**
4 x 1/2" BSP. Please refer to control option on page 45.
-  **AIR VENTS**
Air vent and plug packs are included in the packaging.
-  **OPERATING PRESSURES**
Tested to a pressure of 8 bar.
Working pressure of up to 6.0 bar.
-  **OPERATING TEMPERATURE**
Surface temperature below 43°C.
Water inlet temperature up to 82°C.
-  **DELIVERY**
2 - 5 working days.
Non-stocked items: 3 - 4 weeks.
-  **VALVES**
Please see page 45.
-  **BIM**
Visit our website for quick access to BIM Library components:
www.ringson.co.uk/profile/specifier

For more general information, please see page 266.

Weights & water contents per radiator - LST VERTICAL

Nominal Length (mm)	Nominal Height (mm)		
	1772	2072	2072
420	Weight (kg)	Water Content (l)	Water Content (l)
570	55.26	5.90	61.08
720	69.89	8.85	77.14
870	84.78	11.80	90.50
	99.25	14.75	105.87
			16.20

n-Coefficients

Type	Nominal Height (mm)
22	1772
LSP	1,3581
	1,3452

Heat outputs

LST VERTICAL - Nominal Depth 157mm

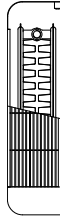

Nominal Height	Outer Casing Nominal Length (mm)	Heat Outputs @ ΔT 50°C		Heat Outputs @ ΔT 30°C		Order Code
		Watts	Btu/h	Watts	Btu/h	
1772mm	420	811	2768	405	1383	17 LSP 042
	570	1217	4152	608	2074	17 LSP 057
	720	1623	5537	811	2766	17 LSP 072
2072mm	870	2028	6921	1013	3457	17 LSP 087
	420	895	3054	450	1535	20 LSP 042*
	570	1342	4579	675	2303	20 LSP 057
	720	1789	6104	900	3071	20 LSP 072
	870	2237	7633	1125	3839	20 LSP 087

*Non-stock - made to order only.

Bracket positions & dimensions

Casing Width - A	420	570	720	870
Radiator Width - B	300	450	600	750
Centre Connections - C	50	50	50	50
Left-Right Connections - D	2444	394	544	694

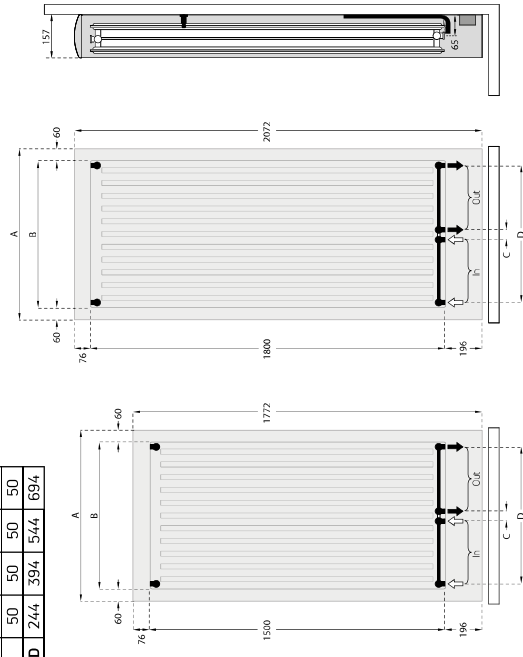

Important: It is advisable to leave a further 5mm clearance above any final floor covering to allow for easy fitting and removal.

NB: All measurements are nominal.

Universal Close Coupled TRV Kit (supplied separate)

LST Vertical radiators can only be fitted with the Universal Close Coupled TRV Kit.
Note: Please discard the 2 integration elbows from the Close Coupler Kit and use the straight valve tails (supplied with the Vertical LST).

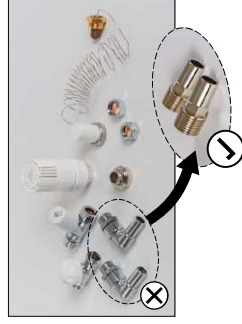

- Universal Close Coupled TRV Kit comprises:**
- 1 x TRV head**
 - 1 x TRV straight body**
 - 1 x LST capillary unit/actuator/sensor head adaptor
 - 1 x MATCHMASTER straight lockshield valve
 - 2 x integration elbows

Order Code: LSTUNIKITUK

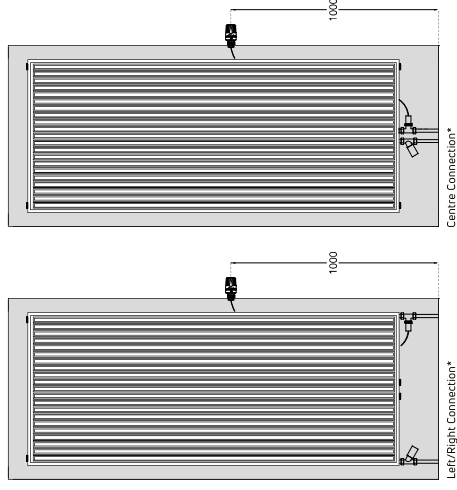

*Flow = left and Return = right for both connection options. Please refer to the diagrams above.
 **15mm compression copper only - for 1/2" iron pipe, an additional female adaptor is required.



LST TRV KITS

MYSON offer a flexible and comprehensive range of chrome TRV kits that are specifically designed to maximise the effectiveness of our range of LST radiators. For information on our LST range please see page 38.

We offer three designs, the Close Coupled Kit and the Universal Close Coupled Kit, which allows the case to be removed for cleaning without removing the TRV head, and the competitively priced Direct Fit Kit. All of the kits come with our A-rated TRV and are expertly designed for precision control.

The kits allow the thermal sensing head of a MYSON Thermostatic Radiator Valve to be mounted directly onto the LST enclosure of a MYSON Low Surface Temperature Radiators. They also feature a locking facility that prevents unauthorised adjustment in public areas.

General specification

- CERTIFICATION**
Produced under a quality management system - ISO 9001:2008. Manual valve conforms to BS 2767-10 and TRV complies to EN 215-1.
- GUARANTEE**
2 year guarantee from date of purchase against manufacturing defects.
- COLOUR**
Finished in chrome.
- CONNECTIONS**
Compression and screwed iron (direct fit only).
- OPERATING PRESSURES**
Operating pressure 10 bar (compression).
- OPERATING TEMPERATURE**
Operating temperature 120°C (compression).
- DELIVERY**
2 - 5 working days.

For more general information, please see page 266.

DIRECTFIT

Direct fit TRV kit

Available for all LST's except Vertical and 420mm wide. Suitable for TBOE connection only. This kit allows a MYSON TRV to be mounted directly onto the internal radiator, making it an integral part of the LST casing. This option utilises the 38mm knock out in the LST casing.

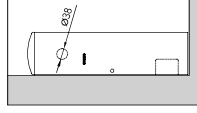
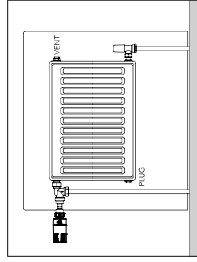

Direct Fit TRV Kit comprises:

- 1 x Horizontal angle TRV body
 - 1 x TRV head
 - 1 x Extension adaptor
 - 1 x Plastic bush
 - 1 x MATCHMASTER lockshield valve
- Order Code: LSTDIRECTKITUK



Close coupled TRV kit

Available for all LST's except Vertical and 420mm wide. Suitable for TBOE, TBSE or BOE connections. This kit allows the MYSON TRV to be mounted directly onto the LST casing, with a choice of positions for both the TRV head and TRV angled valve body. This option utilises the 23mm knock out on the LST casing.

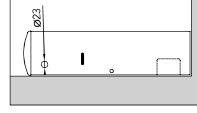
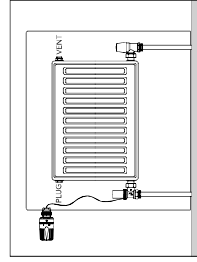

Close Coupled TRV Kit comprises:

- 1 x TRV head
 - 1 x TRV angled body
 - 1 x LST capillary unit/actuator/sensor head adaptor
 - 1 x MATCHMASTER angled lockshield valve
 - 1 x Locking tool
- Order Code: LSTCKKITUK



Universal close coupled TRV kit*

Available for all LST's. Suitable for TBOE, TBSE or BOE connections. This kit allows the MYSON TRV to be mounted directly onto the LST casing, with a choice of positions for both the TRV head and TRV straight valve body. This option utilises the 23mm knock out on the LST casing.

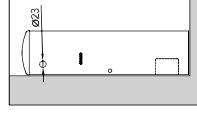
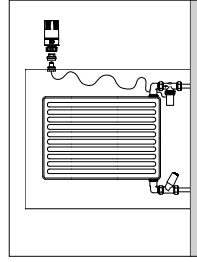

Universal Close Coupled TRV Kit Comprises:

- 1 x TRV head**
 - 1 x TRV straight body**
 - 1 x LST capillary unit/actuator/sensor head adaptor
 - 1 x MATCHMASTER straight lockshield valve
 - 2 x Integration elbows
- Order Code: LSTUNIKITUK



*For LST Vertical instructions, please refer to page 46. **15mm compression copper only - for 1/2" iron pipe, an additional female adaptor is required.

LST TRV kits

Description	Colour (Top)	Order Code	Minimum Order Qty
Direct Fit Kit (1/2" Copper or 1/2" BSP) IRELAND Chrome*	White	LSTDIRECTKITIE	1
Direct Fit Kit (15mm Copper or 1/2" BSP) UK Chrome	White	LSTDIRECTKITUK	1
Universal Close Coupled Kit (1/2" Copper) IRELAND Chrome*	White	LSTUNIKITIE	1
Universal Close Coupled Kit (15mm Copper) UK Chrome	White	LSTUNIKITUK	1
Close Coupled Kit (1/2" Copper) IRELAND Chrome*	White	LSTCKKITIE	1
Close Coupled Kit (15mm Copper) UK Chrome	White	LSTCKKITUK	1

LST TRV kit accessories

Capillary Assembly - 2m	-	LSTCAP2	1
TRV Head Locating Body Chrome	White	LSTTRVHLB	1

*ROI only.

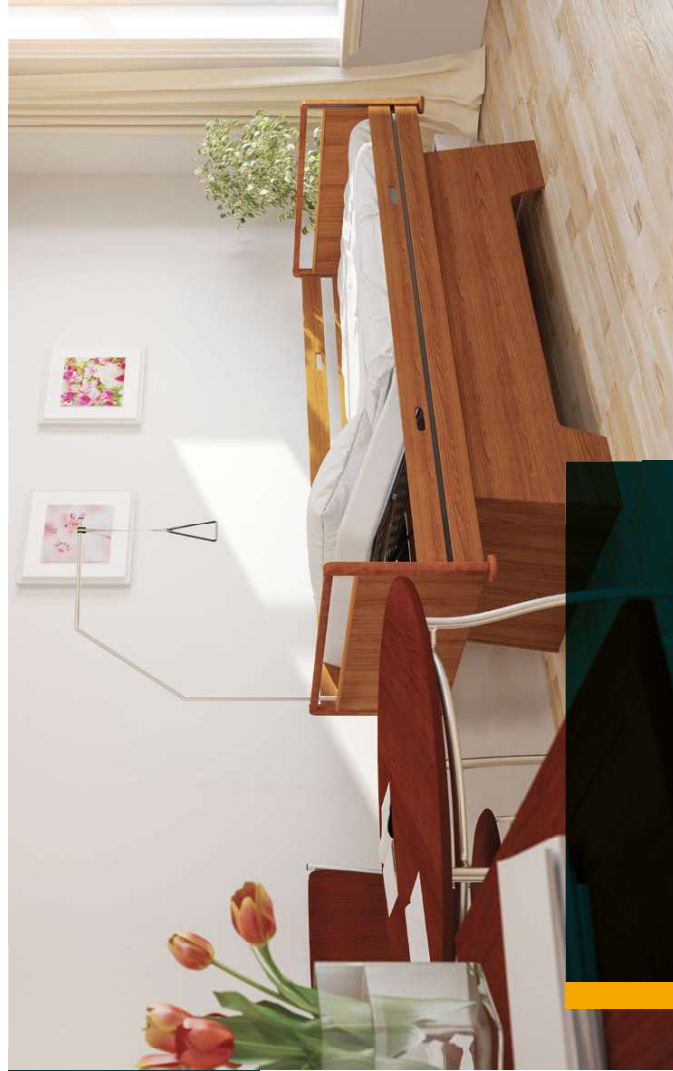

REMOTE THERMOSTATS

The MYSON remote sensor incorporates a traditional TRV head which can be set to the desired temperature.

The room temperature is monitored via a 2, or 5 metre capillary connected to the sensing element which can be mounted in a convenient and temperature representative area of the room. Remote sensor heads are ideal for use when it is difficult for a traditional TRV to operate, such as behind furniture or in direct sunlight, and are primarily used with LST radiators.

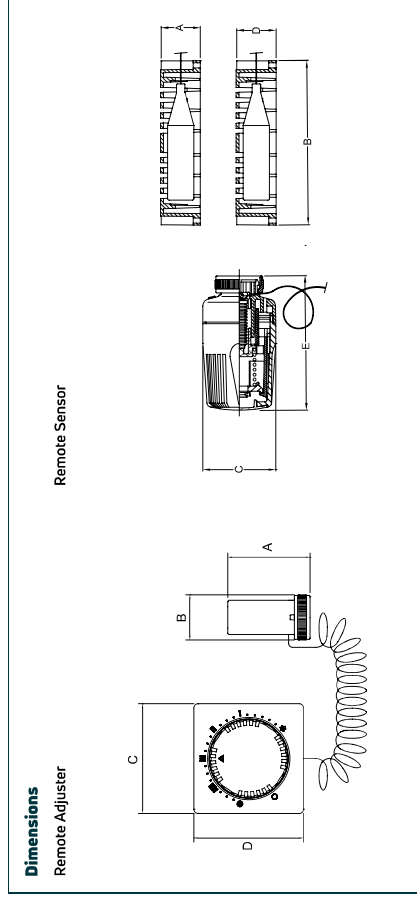

Model		A (mm)	B (mm)	C (mm)	D (mm)	E (mm)
REMOTE ADJUSTER	2/5m Capillary	70	32.5	75	117	-
REMOTE SENSOR	2/5m Capillary	25	63	40	43	83

NB: All measurements are nominal.

General specification



CERTIFICATION
Produced under a quality management system - ISO 9001:2008.



GUARANTEE
2 year guarantee from date of purchase against manufacturing defects.



DELIVERY
2 - 5 working days.

For more general information, please see page 266.



Description	Colour (Top)	Order Code	Minimum Order Qty
Remote Adjustable Head - 2m	White	REMADJ-HEAD2	1
Remote Adjustable Head - 5m	White	REMADJ-HEAD5	1
Remote Sensor Head - 2m	White	REMSENHEAD2	1
Remote Sensor Head - 5m	White	REMSENHEAD5	1

MYSON LST.

The UK's leading low surface temperature radiator



TRV kits
are now supplied
with 'A' rated
thermostatic radiator
valves for energy
efficiency

heatingthroughinnovation.



MYSON LST.

The UK's leading low surface temperature radiator

For reasons of safety, there are a number of situations where radiators with high surface temperatures cannot be used. In those places, typically where vulnerable people are present, LST radiators are the ideal heating solution.

MYSON LST ensures that the surface temperature of the radiator remains under 43°C, so it is the perfect heating method for hospitals, retirement homes, sheltered housing, nurseries, schools, sports halls and children's rooms.



Feature

Surface temperature remains under 43°C.

Rounded steel enclosure with no sharp edges, finished in high quality white paint (RAL 9016).

Simple, double security screw mechanism on casing.

Manufacturer's ten year warranty.

Comply with NHS Estates Health Guidance Notes 1998.

Comprehensive range of models and sizes available.

LST packed in single, protective cardboard carton, which includes emitter, casing, brackets, plug, installation manual and template.

Theft and vandal resistant ring and collar are available for MYSON TRVs (thermostatic radiator valves).

Manufactured and tested to BS EN 442 plus they carry the BS Kitemark.

Benefit

Minimises risk of burns.

Minimises risk of injury, protects the heat emitter and conceals pipework and valves.

Provides easy access/removal for cleaning, maintenance and decorating.

Gives full cover against defects caused by faulty materials or manufacture.

Approved for use in hospitals.

Offers flexibility for all requirements.

Individually packed to provide a single box solution and ensures unit arrives in good condition.

Provides protection against interference and theft.

Certifies independent approval of heat output and verifies production under a quality system to BS EN ISO 9001:2000

Think you've found a better deal elsewhere?

We'll provide a like for like quotation against any of our competitors. Plus, we'll do a spec break!



BS EN 442

Heat Outputs

LST Super Depth 107 mm / 4.21 in



LST Super Plus Depth 157 mm / 6.18 in



Nominal Height* 550 mm 22 in

Outer Casing Length (mm - inches)	Heat Outputs @ ΔT 50°C		Heat Outputs @ ΔT 30°C		Order Code	Heat Outputs @ ΔT 50°C		Heat Outputs @ ΔT 30°C		Order Code
	Watts	Btu/h	Watts	Btu/h		Watts	Btu/h	Watts	Btu/h	
800 - 31	277	946	139	475	5 LS 080	545	1861	276	942	5 LSP 080
1000 - 39	370	1261	186	634	5 LS 100	727	2481	368	1256	5 LSP 100
1200 - 47	462	1576	232	792	5 LS 120	909	3102	460	1571	5 LSP 120
1600 - 63	647	2207	325	1109	5 LS 160	1273	4342	644	2199	5 LSP 160
2000 - 79	832	2837	418	1426	5 LS 200	1636	5583	829	2827	5 LSP 200

Nominal Height* 650 mm 25 in

600 - 24	243	830	123	418	6 LS 060	468	1597	238	811	6 LSP 060
800 - 31	365	1245	184	627	6 LS 080	702	2395	357	1217	6 LSP 080
1000 - 39	486	1660	245	836	6 LS 100	936	3194	475	1622	6 LSP 100
1200 - 47	608	2074	306	1045	6 LS 120	1170	3992	594	2028	6 LSP 120
1400 - 55	730	2489	368	1254	6 LS 140	1404	4790	713	2433	6 LSP 140
1600 - 63	851	2904	429	1463	6 LS 160	1638	5589	832	2839	6 LSP 160
1800 - 71	973	3319	490	1672	6 LS 180	1872	6387	951	3244	6 LSP 180
2000 - 79	1094	3734	551	1881	6 LS 200	2106	7186	1070	3650	6 LSP 200

Nominal Height* 850 mm 33 in

600 - 24	353	1205	179	610	8 LS 060	659	2249	337	1150	8 LSP 060
800 - 31	530	1808	268	915	8 LS 080	989	3374	505	1724	8 LSP 080
1000 - 39	706	2410	358	1221	8 LS 100	1318	4498	674	2299	8 LSP 100
1200 - 47	883	3013	447	1526	8 LS 120	1648	5623	842	2874	8 LSP 120
1400 - 55	1060	3615	537	1831	8 LS 140	1978	6748	1011	3449	8 LSP 140
1600 - 63	1236	4218	626	2136	8 LS 160	2307	7872	1179	4023	8 LSP 160
1800 - 71	1413	4820	716	2441	8 LS 180	2637	8997	1348	4598	8 LSP 180
2000 - 79	1589	5423	805	2746	8 LS 200	2966	10121	1516	5173	8 LSP 200

Nominal Height* 950 mm 37 in

600 - 24	405	1383	206	702	9 LS 060	747	2548	383	1306	9 LSP 060
800 - 31	608	2074	309	1053	9 LS 080	1120	3822	574	1959	9 LSP 080
1000 - 39	810	2765	412	1404	9 LS 100	1494	5096	766	2613	9 LSP 100
1200 - 47	1013	3456	514	1755	9 LS 120	1867	6370	957	3266	9 LSP 120
1400 - 55	1216	4148	617	2106	9 LS 140	2240	7644	1149	3919	9 LSP 140
1600 - 63	1418	4839	720	2457	9 LS 160	2614	8918	1340	4572	9 LSP 160
1800 - 71	1621	5530	823	2808	9 LS 180	2987	10192	1531	5225	9 LSP 180

*Please ensure you add an extra 22mm to the height of the radiator to account for the curvature of the top grille.

N.B. The tabulated heat outputs are quoted at a mean water to air temperature difference of 50°C and 30°C. The standard heat outputs are based on length of the internal heat emitter, not the outer casing.

Connections

All MYSON LST radiators are fitted with 4 - 1/2 inch BSP connections.

Operating Pressures

Every MYSON LST radiator is tested to a pressure of 10.5 bar (152.5 psi) and is suitable for a working pressure of up to 8.0 bar (117.1 psi).

Weight and Water Content per Radiator (LST Super)

Length (mm)	Height (mm)							
	550		650		850		950	
	Weight (kg)	Water Content (l)	Weight (kg)	Water Content (l)	Weight (kg)	Water Content (l)	Weight (kg)	Water Content (l)
600			11.02	1.20	15.32	1.80	17.22	2.04
800	12.10	1.28	14.90	1.60	20.90	2.40	23.53	2.72
1000	15.22	1.60	18.80	2.00	26.50	3.00	29.88	3.40
1200	18.45	1.92	22.69	2.40	32.09	3.60	36.21	4.08
1400			26.62	2.80	37.73	4.20	42.57	4.76
1600	24.80	2.56	30.56	3.20	43.37	4.80	48.94	5.44
1800			34.53	3.60	49.04	5.40	55.34	6.12
2000	31.07	3.20	38.40	4.00	54.62	6.00		

Weight and Water Content per Radiator (LST Super Plus)

Length (mm)	Height (mm)							
	550		650		850		950	
	Weight (kg)	Water Content (l)	Weight (kg)	Water Content (l)	Weight (kg)	Water Content (l)	Weight (kg)	Water Content (l)
600			16.28	2.46	23.04	3.54	26.07	4.14
800	17.92	2.56	22.36	3.28	31.88	4.72	36.18	5.52
1000	22.70	3.20	28.44	4.10	40.72	5.90	46.32	6.90
1200	27.50	3.84	34.52	4.92	49.59	7.08	56.45	8.28
1400			40.61	5.74	58.44	8.26	66.57	9.66
1600	37.12	5.12	46.74	6.56	67.33	9.44	76.73	11.04
1800			52.88	7.38	76.24	10.62	86.91	12.42
2000	46.74	6.40	58.94	8.20	85.06	11.80		

Bracket Positions and Dimensions

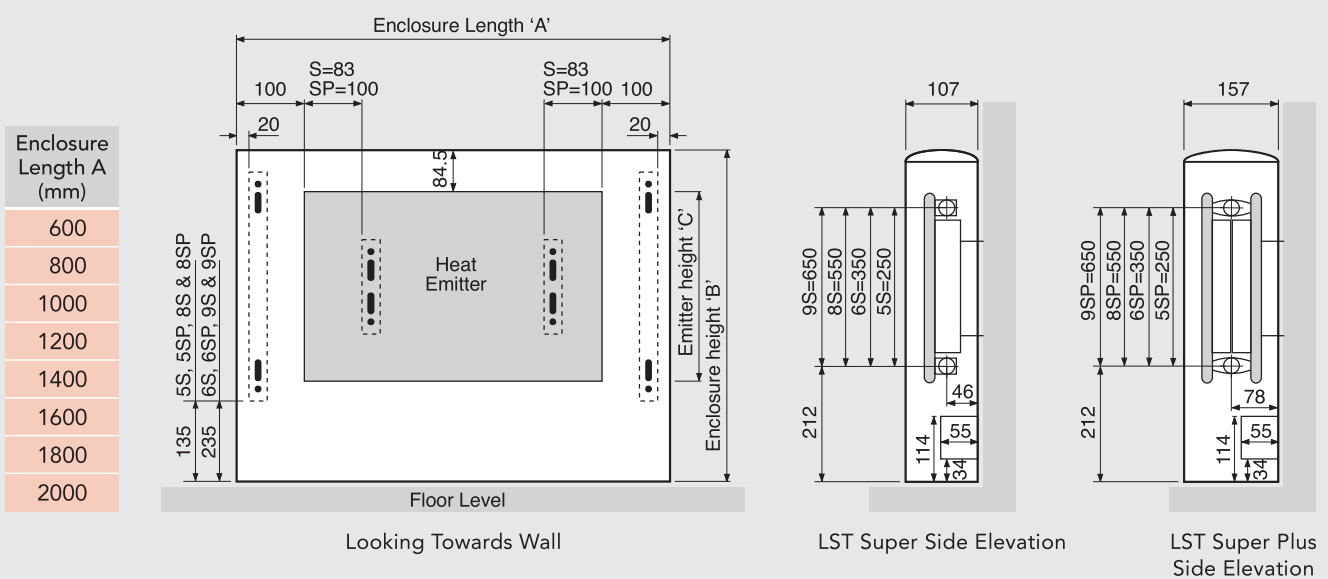

Enclosure Height* B (mm)	572	672	872	972
Emitter Height C (mm)	300	400	600	700

*This measurement includes an extra 22mm to account for the curvature of the top grille.

Important: It is advisable to leave a further 5mm clearance above any final floor covering to allow for easy fitting and removal.

LST Thermostatic Radiator Valve Kits (TRV)

TRVs allow the temperature of each room to be automatically and precisely controlled. Each valve has an adjustable temperature setting enabling pre-selection of the chosen temperature for that room. When thermostatic control is required, **MYSON** offers a comprehensive range of TRVs to suit all applications.



TRV kits are now supplied with 'A' rated thermostatic radiator valves for energy efficiency

Valve Type	Order Code	Connection Options
Close Coupled TRV Kit*	CCKTC	TBOE or BOE
Direct Fit TRV Kit*	DIRECTFIT	TBOE
Remote Sensor*	2TRVRSHEAD5 (5 metre) 2TRVRSHEAD2 (2 metre)	BOE
Remote Adjuster	2TRVADJHEAD5 (5 metre) 2TRVADJHEAD2 (2 metre)	TBOE or BOE

* Supplied with 'A' rated thermostatic radiator valves.

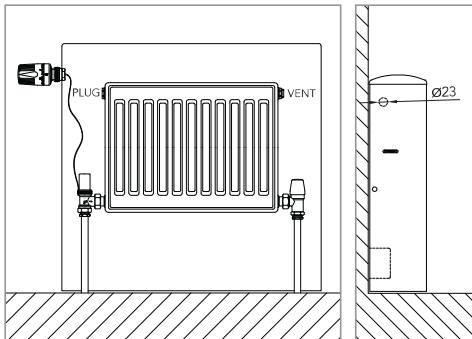

Close Coupled Kit

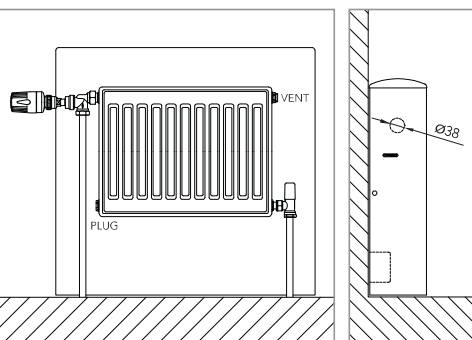

Direct Fit Kit

Close Coupled TRV Kit

Suitable for TBOE or BOE connections.

This arrangement offers a choice of positions for both the valve body and sensor head.

The kit allows the thermal sensing head of a **MYSON** Thermostatic Radiator Valve to be mounted directly on the top left/right hand side of the **LST** enclosure. The point of fitting has been half-sheared and requires only to be knocked out to facilitate easy installation, becoming an integral part of the appliance.

The valve body is fitted to the heat emitter and is coupled to the sensing head by a flexible capillary extension lead.

Direct Fit TRV Kit

Suitable for TBOE connection only.

This kit allows a **MYSON** TRV body to be directly fitted to the radiator, with the thermostatic head projecting beyond the enclosure.

Remote Sensor

This allows the TRV head to be fitted inside the **LST** casing. The TRV valve body must be fitted on bottom opposite end of the radiator. It is NOT suitable for top end connection. The sensor may be positioned up to 5 metres from the casing.

Remote Adjuster

Suitable for TBOE or BOE connections.

The TRV head/sensor is mounted directly onto a wall plate and may be fitted up to 5 metres from the emitter.